



LEAPTON
SOLAR

Monofacial

Bifacial

LP182*182-M-54-MH

Rated Power 400-415W



MBB Cell
New circuit design, lower internal current, lower internal resistance loss.



Low Light Features
Higher performance under low light environment.



Higher Output Power
Module adopts 108 pcs of 182*182mm half cells, the maximum power can reach 415W.



PID Protection
Ensure the attenuation probability caused by PID phenomenon is minimized.



Harsh Environmental Adaptability
Strict salt spray and ammonia corrosion test by TUV Nord.



Load Capacity
Mechanical load tests including wind load 2400 Pa and snow load 5400 Pa done by TUV Nord.

■ Leapton Linear Power Warranty ■ Industry Warranty

0.55% Annual Degradation over 25 years

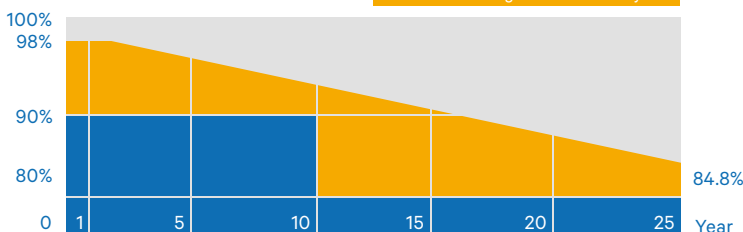

IEC 61215-2: 2016
IEC 61730-2: 2016



Headquarter : Leapton Energy Co., Ltd.

📍 Tosei Bldg. 6F, 1-2-1 Aioi-cho, Chuo-ku Kobe-shi, Hyogo, 650-0025, Japan

☎ +81-78-382-3182

🌐 www.leaptonenergy.jp

Manufacturer : Leapton Solar (Changshu) Co., Ltd.

📍 No.9, Sunshine Avenue, Changshu City, Jiangsu, China

☎ +86-512-88800068

✉ info@leaptonenergy.com

🌐 www.leaptonpv.com

MECHANICAL DIAGRAMS

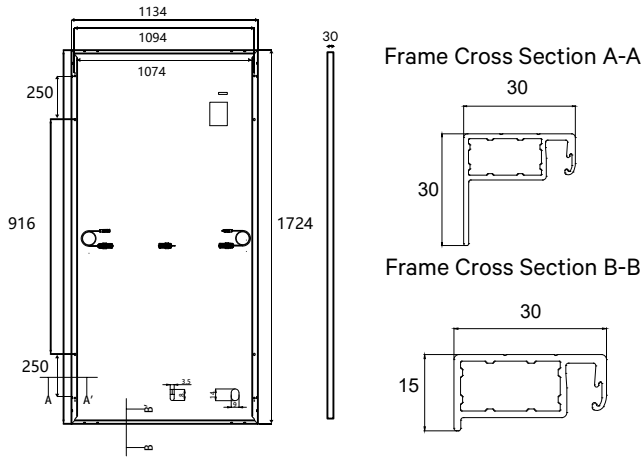

SPECIFICATIONS

Weight	21kg
Dimensions	1724mm*1134mm*30mm
Cell Dimensions	182*182mm
Cell Amount	54*2 pcs
Maximum System Voltage	1500V
Junction Box	IP68
Frame	Aluminum Alloy
Cable	4mm ² , N 1100mm/P 1100mm or customized length
Connector	MC4 compatible
Application Level	Class A

ELECTRICAL PARAMETERS AT STC

Power	400W	405W	410W	415W
Open Circuit Voltage	36.94V	37.14V	37.34V	37.54V
Short Circuit Current	13.60A	13.65A	13.70A	13.75A
Maximum Power Voltage	30.92V	31.12V	31.32V	31.62V
Maximum Power Current	12.94A	13.00A	13.06A	13.12A
Module Efficiency	20.46%	20.72%	20.97%	21.27%

* Under Standard Test Conditions (STC) of irradiance of 1000 W/m², spectrum AM 1.5 and cell temperature of 25°C.

ELECTRICAL PARAMETERS AT NMOT

Power	295W	298W	302W	306W
Open Circuit Voltage	34.49V	34.69V	34.89V	35.09V
Short Circuit Current	10.70A	10.75A	10.80A	11.00A
Maximum Power Voltage	28.78V	28.98V	29.18V	29.38V
Maximum Power Current	10.25A	10.28A	10.35A	10.40A
Module Efficiency	15.09%	15.24%	15.45%	15.66%

* Under Nominal Module Operating Temperature (NMOT), irradiance of 800 W/m², spectrum AM 1.5, ambient temperature 20°C, wind speed 1 m/s.

TEMPERATURE CHARACTERISTICS

NMOT	41±3°C	Temp Coefficient of ISC	+0.05%/°C
Temp Coefficient of VOC	-0.28%/°C	Temp Coefficient of Pmax	-0.36%/°C

PACKING CONFIGURATION

Modules/Pallet	36 Pieces	Modules/40'Container	936 Pieces
Packing Description	26 Pallets, Total=(36+36)x13=936 Pieces		

CHARACTERISTICS

LP182*182-M-54-MH-400W

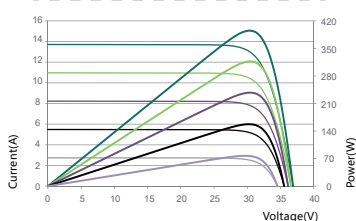

LP182*182-M-54-MH-400W

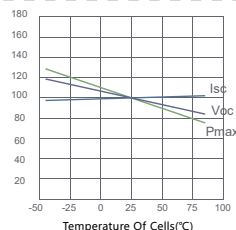

MAXIMUM RATING

Output Tolerance	0~+5W
Operating Temperature	-40°C~+85°C
Wind Load/Snow Load	2400pa/5400pa
Fuse Current	25A



Headquarter : Lepton Energy Co., Ltd.

☑ Tosei Bldg. 6F, 1-2-1 Aioi-cho, Chuo-ku Kobe-shi, Hyogo, 650-0025, Japan

☎ +81-78-382-3182

🌐 www.leptonenergy.jp

Manufacturer : Lepton Solar (Changshu) Co., Ltd.

☑ No.9, Sunshine Avenue, Changshu City, Jiangsu, China

☎ +86-512-88800068

✉ info@leptonenergy.com

🌐 www.leptonpv.com