



Monofacial

Bifacial

LP182*182-M-60-MB

PERC Dual Glass

Rated Power 440-455W



MBB Cell

New circuit design, lower internal current, lower internal resistance loss.



Low Light Features

Higher performance under low light environment.



Bifacial with dual glass

Module adopts 182*182mm half cells, bifacial module provide an additional 5%~25% output.



PID Protection

Ensure the attenuation probability caused by PID phenomenon is minimized.



Harsh Environmental Adaptability

Strict salt spray and ammonia corrosion test by TUV Nord.



Load Capacity

Mechanical load tests including wind load 2400 Pa and snow load 5400 Pa done by TUV Nord.

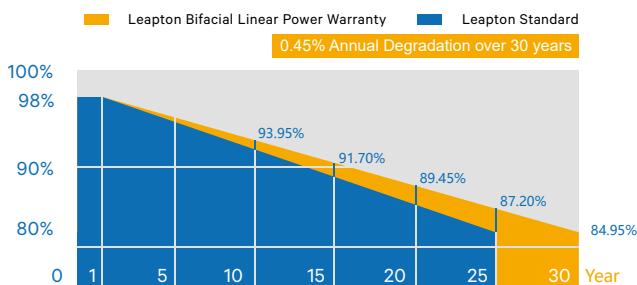

IEC 61215-2: 2016
IEC 61730-2: 2016



Headquarter : Leapton Energy Co., Ltd.

Tosei Bldg. 6F, 1-2-1 Aioi-cho, Chuo-ku Kobe-shi, Hyogo, 650-0025, Japan

+81-78-382-3182

www.leaptonenergy.jp

Manufacturer : Leapton Solar (Changshu) Co., Ltd.

No.9, Sunshine Avenue, Changshu City, Jiangsu, China

+86-512-88800068

info@leaptonenergy.com

www.leaptonpv.com

MECHANICAL DIAGRAMS

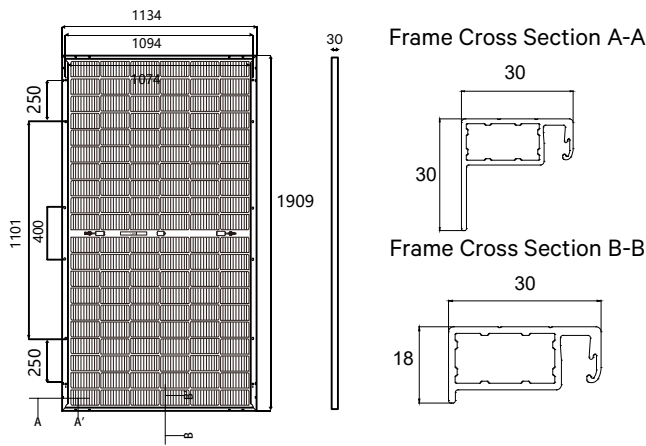

SPECIFICATIONS

Weight	26.5kg
Dimensions	1909mm*1134mm*30mm
Cell Dimensions	182*182mm
Cell Amount	60*2 pcs
Maximum System Voltage	1500V
Junction Box	IP68
Frame	Aluminum Alloy
Cable	4mm ² , N 1200mm/P 1200mm or customized length
Connector	MC4 compatible
Application Level	Class A
Bifaciality	70±5%

ELECTRICAL PARAMETERS AT STC

Power	440W	445W	450W	455W
Open Circuit Voltage	41.00V	41.20V	41.40V	41.60V
Short Circuit Current	13.58A	13.63A	13.68A	13.73A
Maximum Power Voltage	34.20V	34.50V	34.70V	34.90V
Maximum Power Current	12.84A	12.90A	12.96A	13.02A
Module Efficiency	20.33%	20.56%	20.79%	21.02%

* Under Standard Test Conditions (STC) of irradiance of 1000 W/m², spectrum AM 1.5 and cell temperature of 25°C.

ELECTRICAL PARAMETERS AT NMOT

Power	324W	328W	331W	335W
Open Circuit Voltage	38.28V	38.48V	38.68V	38.88V
Short Circuit Current	10.68A	10.73A	10.78A	10.83A
Maximum Power Voltage	31.94V	32.14V	32.34V	32.54V
Maximum Power Current	10.14A	10.21A	10.24A	10.30A
Module Efficiency	14.97%	15.15%	15.29%	15.47%

* Under Nominal Module Operating Temperature (NMOT), irradiance of 800 W/m², spectrum AM 1.5, ambient temperature 20°C, wind speed 1 m/s.

ELECTRICAL PARAMETERS (AT 10% BIFACIAL POWER OUTPUT)

Output Power	484W	490W	495W	501W
Open Circuit Voltage	41.00V	41.20V	41.40V	41.60V
Short Circuit Current	14.94A	14.99A	15.05A	15.10A
Maximum Power Voltage	34.20V	34.40V	34.60V	34.80V
Maximum Power Current	14.15A	14.23A	14.31A	14.38A

TEMPERATURE CHARACTERISTICS

NMOT	41±3°C	Temp Coefficient of ISC	+0.05%/°C
Temp Coefficient of VOC	-0.265%/°C	Temp Coefficient of Pmax	-0.34%/°C

PACKING CONFIGURATION

Modules/Pallet	36 Pieces	Modules/40'Container	864 Pieces
----------------	-----------	----------------------	------------

Packing Description 24 Pallets, Total=(36+36)x12=864 Pieces

CHARACTERISTICS

LP182*182-M-60-MB-450W

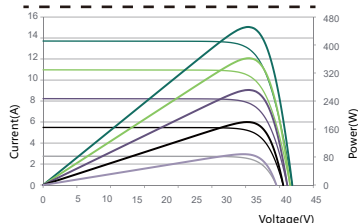

LP182*182-M-60-MB-450W

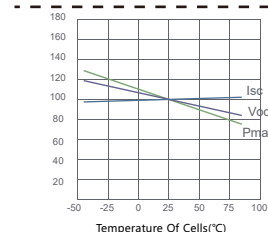

MAXIMUM RATING

Output Tolerance	0~+5W
Operating Temperature	-40°C~+85°C
Wind Load/Snow Load	2400pa/5400pa
Fuse Current	25A

15 YEARS Quality Warranty

30 YEARS Power Warranty

Headquarter : Lepton Energy Co., Ltd.

📍 Tosei Bldg. 6F, 1-2-1 Aioi-cho, Chuo-ku Kobe-shi, Hyogo, 650-0025, Japan

☎ +81-78-382-3182

🌐 www.leptonenergy.jp

Manufacturer : Lepton Solar (Changshu) Co., Ltd.

📍 No.9, Sunshine Avenue, Changshu City, Jiangsu, China

☎ +86-512-88800068

✉ info@leptonenergy.com

🌐 www.leptonpv.com