



Monofacial

Bifacial

# LP182\*182-M-60-NH

## N-Type TOPCon

Rated Power 460-480W



**N-Type MBB Cell**  
New circuit design N-type cells, can increase the output power of 10W~20W



**Low Light Features**  
Higher performance under low light environment.



**Higher Output Power**  
Module adopts 120 pcs of 182\*182mm half cells, the maximum power can reach 480W.



**PID Protection**  
Ensure the attenuation probability caused by PID phenomenon is minimized.



**Harsh Environmental Adaptability**  
Strict salt spray and ammonia corrosion test by TUV Nord.



**Load Capacity**  
Mechanical load tests including wind load 2400 Pa and snow load 5400 Pa done by TUV Nord.

Leapton N-Type Linear Power Warranty    Industry Warranty

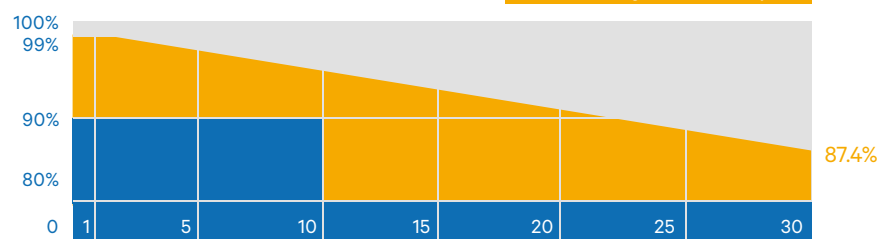

## MECHANICAL DIAGRAMS

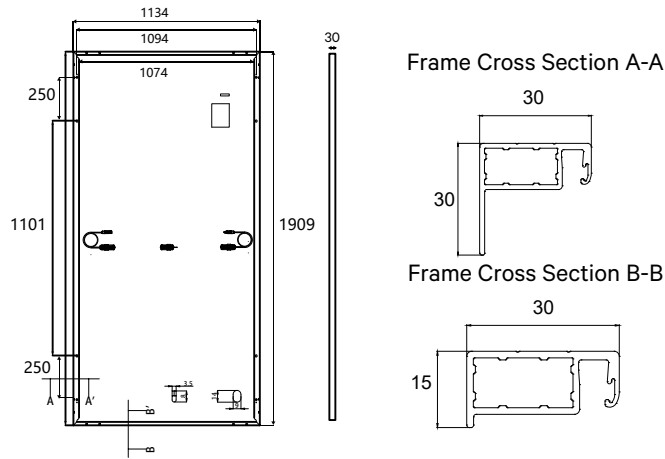

## SPECIFICATIONS

Weight	23kg
Dimensions	1909mm*1134mm*30mm
Cell Dimensions	182*182mm
Cell Amount	60*2 pcs
Maximum System Voltage	1500V
Junction Box	IP68
Frame	Aluminum Alloy
Cable	4mm <sup>2</sup> , N 1200mm/P 1200mm or customized length
Connector	MC4 compatible
Application Level	Class A

## ELECTRICAL PARAMETERS AT STC

Power	460W	465W	470W	475W	480W
Open Circuit Voltage	42.13V	42.30V	42.46V	42.62V	42.79V
Short Circuit Current	13.97A	14.05A	14.13A	14.21A	14.29A
Maximum Power Voltage	34.78V	34.95V	35.11V	35.27V	35.44V
Maximum Power Current	13.23A	13.31A	13.39A	13.47A	13.55A
Module Efficiency	21.25%	21.48%	21.71%	21.94%	22.17%

\* Under Standard Test Conditions (STC) of irradiance of 1000 W/m<sup>2</sup>, spectrum AM 1.5 and cell temperature of 25°C.

## ELECTRICAL PARAMETERS AT NMOT

Power	346W	350W	354W	358W	361W
Open Circuit Voltage	40.02V	40.18V	40.33V	40.49V	40.65V
Short Circuit Current	11.27A	11.34A	11.40A	11.47A	11.53A
Maximum Power Voltage	32.70V	32.87V	33.04V	33.20V	33.37V
Maximum Power Current	10.59A	10.65A	10.71A	10.77A	10.83A
Module Efficiency	15.98%	16.17%	16.35%	16.54%	16.68%

\* Under Nominal Module Operating Temperature (NMOT), irradiance of 800 W/m<sup>2</sup>, spectrum AM 1.5, ambient temperature 20°C, wind speed 1 m/s.

## TEMPERATURE CHARACTERISTICS

NMOT	41±3°C	Temp Coefficient of ISC	+0.046%/°C
Temp Coefficient of VOC	-0.25%/°C	Temp Coefficient of Pmax	-0.30%/°C

## PACKING CONFIGURATION

Modules/Pallet	36 Pieces	Modules/40'Container	864 Pieces
Packing Description	24 Pallets, Total=(36+36)x12=864 Pieces		

## CHARACTERISTICS

LP182\*182-M-60-NH-480W

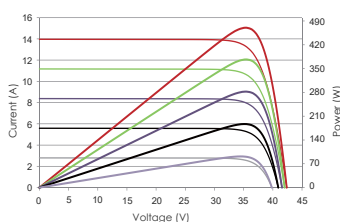

LP182\*182-M-60-NH-480W

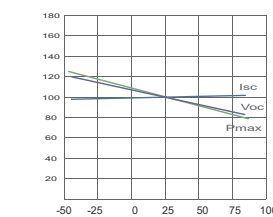

## MAXIMUM RATING

Output Tolerance	0~+5W
Operating Temperature	-40°C~+85°C
Wind Load/Snow Load	2400pa/5400pa
Fuse Current	25A

15 YEARS Quality Warranty

30 YEARS Power Warranty

Headquarter : Lepton Energy Co., Ltd.

📍 Tosei Bldg. 6F, 1-2-1 Aioi-cho, Chuo-ku Kobe-shi, Hyogo, 650-0025, Japan

☎ +81-78-382-3182

🌐 www.leptonenergy.jp

Manufacturer : Lepton Solar (Changshu) Co., Ltd.

📍 No.9, Sunshine Avenue, Changshu City, Jiangsu, China

☎ +86-512-88800068

✉ info@leptonenergy.com

🌐 www.leptonpv.com