



LEAPTON
SOLAR

Monofacial

Bifacial

LP182*210-M-54-NH N-Type TOPCon

Rated Power 490-510W



N-Type 182*210mm Cell
Adopting the 182*210mm N-Type TOPCon solar cells with the highest efficiency.



Low Light Features
Higher performance under low light environment.



Higher Output Power
Module adopts 108 pcs of 182*210mm half cells, the maximum power can reach 510W.



Load Capacity
Mechanical load tests including wind load 2400 Pa and snow load 5400 Pa done by TUV Nord.



Harsh Environmental Adaptability
Strict salt spray and ammonia corrosion test by TUV Nord.



PID Protection
Ensure the attenuation probability caused by PID phenomenon is minimized.

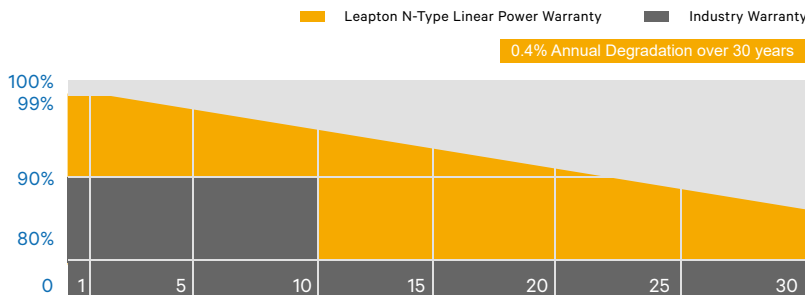

Headquarter : Leapton Energy Co., Ltd.

📍 Tosei Bldg. 6F, 1-2-1 Aioi-cho, Chuo-ku Kobe-shi, Hyogo, 650-0025, Japan

☎ +81-78-382-3182

🌐 www.leaptonenergy.jp

Manufacturer : Leapton Solar (Changshu) Co., Ltd.

📍 No.9, Sunshine Avenue, Changshu City, Jiangsu, China

☎ +86-512-88800068

✉ info@leaptonenergy.com

🌐 www.leaptonpv.com

MECHANICAL DIAGRAMS

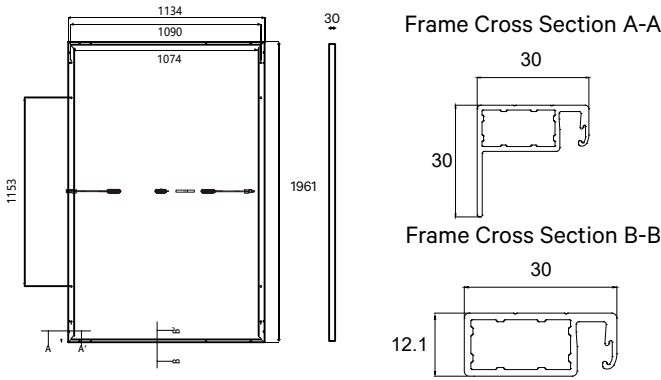

SPECIFICATIONS

Weight	23.7kg
Dimensions	1961mm*1134mm*30mm
Cell Dimensions	182*210mm
Cell Amount	54*2 pcs
Maximum System Voltage	1500V
Junction Box	IP68
Front glass	3.2 mm heat strengthened glass with anti-reflective coating
Frame	Aluminum Alloy
Cable	4mm ² , N 1200mm/P 1200mm for Horizontal installation 4mm ² , N 300mm/P 300mm for Vertical installation
Connector	MC4 compatible

ELECTRICAL PARAMETERS AT STC

Power	490W	495W	500W	505W	510W
Open Circuit Voltage	39.57V	39.82V	40.07V	40.32V	40.57V
Short Circuit Current	15.78A	15.84A	15.90A	15.96A	16.01A
Maximum Power Voltage	32.93V	33.13V	33.33V	33.53V	33.73V
Maximum Power Current	14.88A	14.94A	15.00A	15.06A	15.12A
Module Efficiency	22.03%	22.26%	22.48%	22.71%	22.93%

* Under Standard Test Conditions (STC) of irradiance of 1000 W/m², spectrum AM 1.5 and cell temperature of 25°C.

ELECTRICAL PARAMETERS AT NMOT

Power	373W	377W	381W	384W	389W
Open Circuit Voltage	37.52V	37.79V	38.06V	38.33V	38.60V
Short Circuit Current	12.68A	12.76A	12.79A	12.81A	12.87A
Maximum Power Voltage	30.92V	31.12V	31.32V	31.52V	31.72V
Maximum Power Current	12.06A	12.11A	12.16A	12.18A	12.26A

* Under Nominal Module Operating Temperature (NMOT), irradiance of 800 W/m², spectrum AM 1.5, ambient temperature 20°C, wind speed 1 m/s.

TEMPERATURE CHARACTERISTICS

NMOT	41±3°C	Temp Coefficient of ISC	+0.046%/°C
Temp Coefficient of VOC	-0.25%/°C	Temp Coefficient of Pmax	-0.30%/°C

PACKING CONFIGURATION

Modules/Pallet	36 Pieces	Modules/40'Container	864 Pieces
Packing Description	24 Pallets, Total=(36+36)x12=864 Pieces		

CHARACTERISTICS

LP182*210-M-54-NH-500W

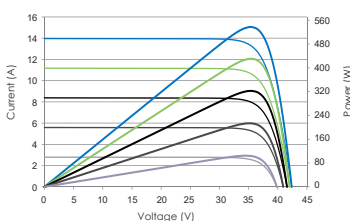

LP182*210-M-54-NH-500W

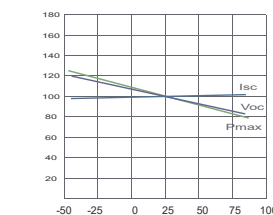

MAXIMUM RATING

Output Tolerance	0~+5W
Operating Temperature	-40°C~+85°C
Wind Load/Snow Load	2400pa/5400pa
Fuse Current	25A

25 YEARS Quality Warranty

30 YEARS Power Warranty

Headquarter : Leapton Energy Co., Ltd.

☑ Tosei Bldg. 6F, 1-2-1 Aioi-cho, Chuo-ku Kobe-shi, Hyogo, 650-0025, Japan

Manufacturer : Leapton Solar (Changshu) Co., Ltd.

☑ No.9, Sunshine Avenue, Changshu City, Jiangsu, China

☎ +81-78-382-3182

🌐 www.leaptonenergy.jp

☎ +86-512-88800068

✉ info@leaptonenergy.com

🌐 www.leaptonpv.com