



Monofacial

Bifacial

# LP182\*182-M-54-NH

## N-Type TOPCon

Rated Power 430-450W

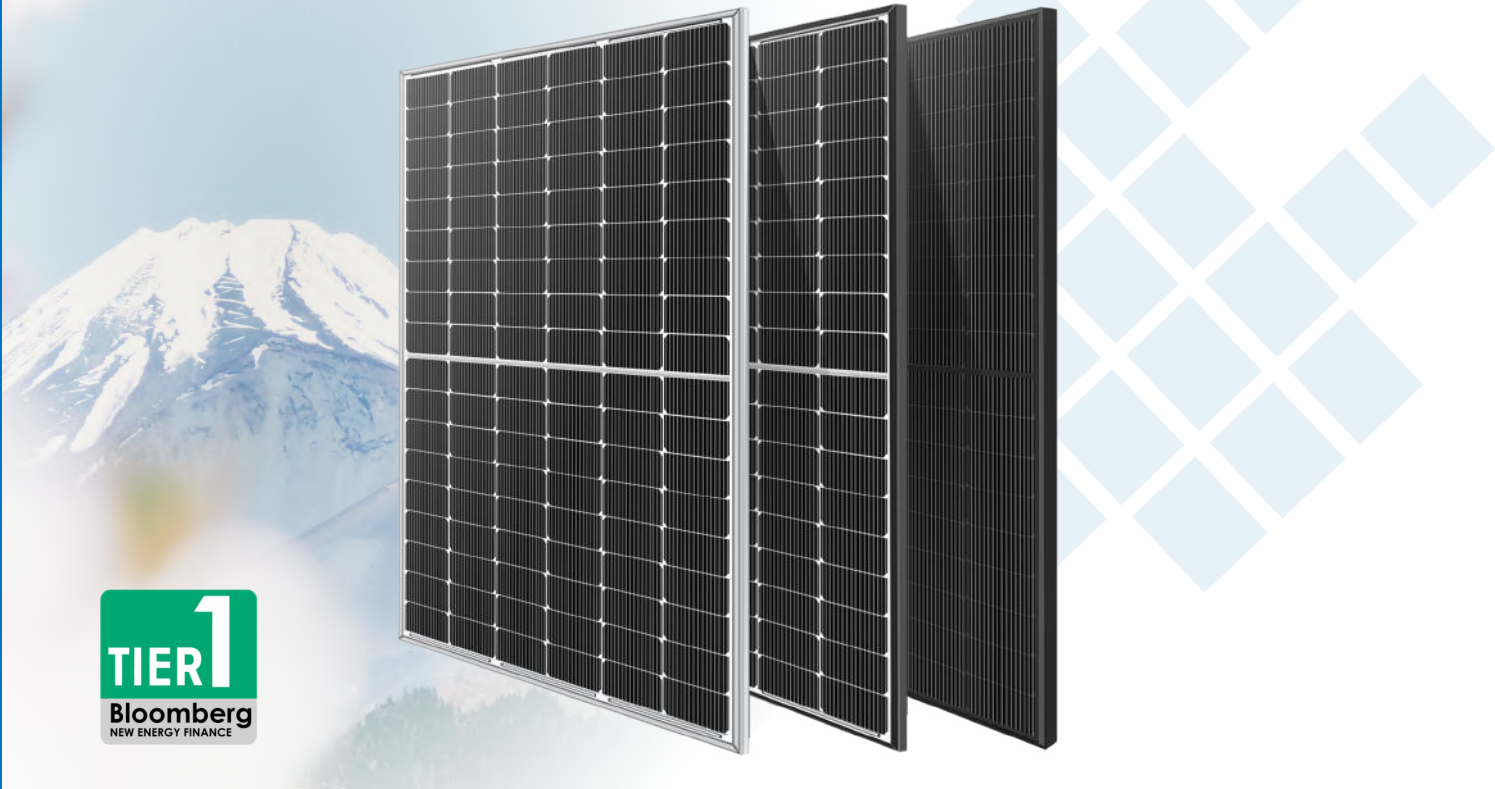

**N-Type MBB Cell**  
New circuit design N-type cells, can increase the output power of 10W-20W



**Higher Output Power**  
Module adopts 108 pcs of 182\*182mm half cells, the maximum power can reach 450W.



**Harsh Environmental Adaptability**  
Strict salt spray and ammonia corrosion test by TUV Nord.



**Low Light Features**  
Higher performance under low light environment.



**PID Protection**  
Ensure the attenuation probability caused by PID phenomenon is minimized.



**Load Capacity**  
Mechanical load tests including wind load 2400 Pa and snow load 5400 Pa done by TUV Nord.

Leapton N-Type Linear Power Warranty Industry Warranty

0.4% Annual Degradation over 30 years

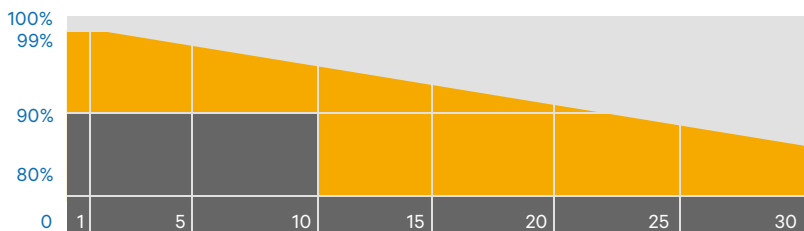

Headquarter : Leapton Energy Co., Ltd.

Tosei Bldg. 6F, 1-2-1 Aioi-cho, Chuo-ku Kobe-shi, Hyogo, 650-0025, Japan

Manufacturer : Leapton Solar (Changshu) Co., Ltd.

No.9, Sunshine Avenue, Changshu City, Jiangsu, China

+81-78-382-3182

www.leaptonenergy.jp

+86-512-88800068

info@leaptonenergy.com

www.leaptonpv.com

## MECHANICAL DIAGRAMS

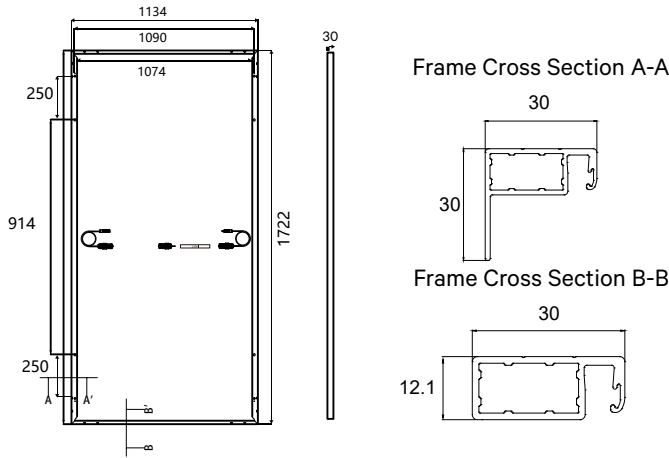

## SPECIFICATIONS

Weight	21kg
Dimensions	1722mm*1134mm*30mm
Cell Dimensions	182*182mm
Cell Amount	54*2 pcs
Maximum System Voltage	1500V
Junction Box	IP68
Front glass	3.2mm, Anti-Reflection Coating, High Transmission, Low Iron, Tempered Glass
Frame	Aluminum Alloy
Cable	4mm <sup>2</sup> , N 1100mm/P 1100mm for Horizontal installation 4mm <sup>2</sup> , N 300mm/P 300mm for Vertical installation
Connector	MC4 compatible

## ELECTRICAL PARAMETERS AT STC

Power	430W	435W	440W	445W	450W
Open Circuit Voltage	38.57V	38.72V	38.87V	39.02V	39.17V
Short Circuit Current	14.09A	14.18A	14.27A	14.36A	14.44A
Maximum Power Voltage	31.76V	31.89V	32.05V	32.20V	32.35V
Maximum Power Current	13.54A	13.64A	13.73A	13.82A	13.91A
Module Efficiency	22.02%	22.28%	22.53%	22.79%	23.04%

\* Under Standard Test Conditions (STC) of irradiance of 1000 W/m<sup>2</sup>, spectrum AM 1.5 and cell temperature of 25°C.

## ELECTRICAL PARAMETERS AT NMOT

Power	324W	327W	331W	335W	339W
Open Circuit Voltage	36.63V	36.78V	36.93V	37.08V	37.23V
Short Circuit Current	11.36A	11.38A	11.45A	11.52A	11.58A
Maximum Power Voltage	29.65V	29.78V	29.93V	30.08V	30.24V
Maximum Power Current	10.93A	10.98A	11.06A	11.14A	11.21A

\* Under Nominal Module Operating Temperature (NMOT), irradiance of 800 W/m<sup>2</sup>, spectrum AM 1.5, ambient temperature 20°C, wind speed 1 m/s.

## TEMPERATURE CHARACTERISTICS

NMOT	41±3°C	Temp Coefficient of ISC	+0.046%/°C
Temp Coefficient of VOC	-0.25%/°C	Temp Coefficient of Pmax	-0.30%/°C

## PACKING CONFIGURATION

Modules/Pallet	36 Pieces	Modules/40'Container	936 Pieces
Packing Description	26 Pallets, Total=(36+36)x13=936 Pieces		

## CHARACTERISTICS

LP182\*182-M-54-NH-440W

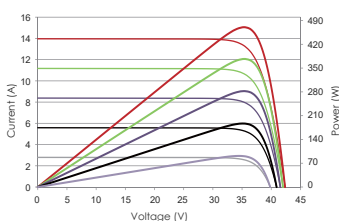

LP182\*182-M-54-NH-440W

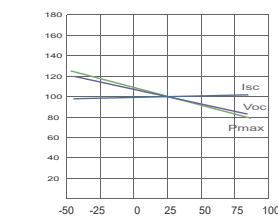

## MAXIMUM RATING

Output Tolerance	0~+5W
Operating Temperature	-40°C~+85°C
Wind Load/Snow Load	2400pa/5400pa
Fuse Current	25A



Headquarter : Lepton Energy Co., Ltd.

☑ Tosei Bldg. 6F, 1-2-1 Aioi-cho, Chuo-ku Kobe-shi, Hyogo, 650-0025, Japan

Manufacturer : Lepton Solar (Changshu) Co., Ltd.

☑ No.9, Sunshine Avenue, Changshu City, Jiangsu, China

☎ +86-512-88800068

✉ info@leptonenergy.com

🌐 www.leptonpv.com

☎ +81-78-382-3182

🌐 www.leptonenergy.jp