

# LP182\*182-M-60-NH N-Type

Rated Power 480-500W



**N-Type MBB Cell**  
New circuit design N-type cells, can increase the output power of 10W~20W



**Low Light Features**  
Higher performance under low light environment.



**Higher Output Power**  
Module adopts 120 pcs of 182\*188mm half cells, the maximum power can reach 500W.



**PID Protection**  
Ensure the attenuation probability caused by PID phenomenon is minimized.



**Harsh Environmental Adaptability**  
Strict salt spray and ammonia corrosion test by TUV Nord.



**Load Capacity**  
Mechanical load tests including wind load 2400 Pa and snow load 5400 Pa done by TUV Nord.

■ Leapton N-Type Linear Power Warranty ■ Industry Warranty

0.4% Annual Degradation over 30 years

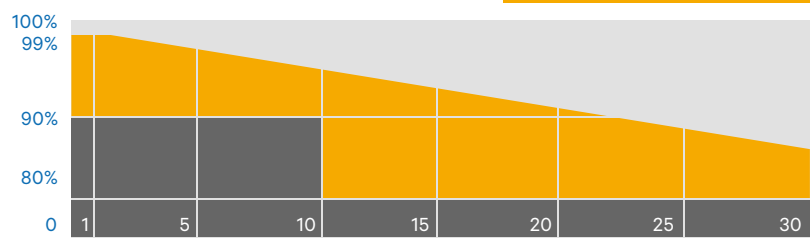

## MECHANICAL DIAGRAMS

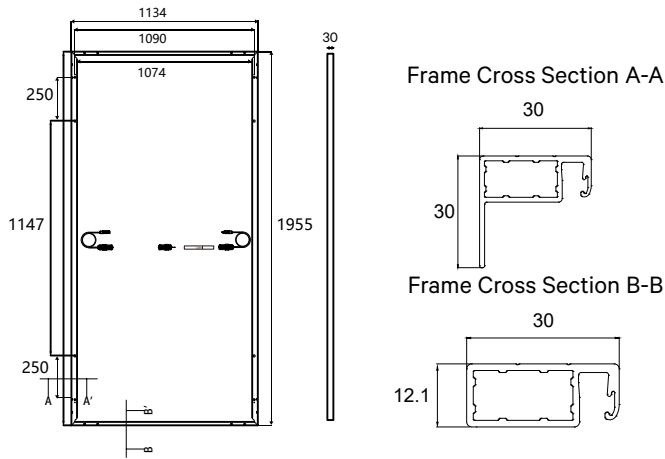

## SPECIFICATIONS

Weight	23.5kg
Dimensions	1955mm*1134mm*30mm
Cell Dimensions	182*188mm
Cell Amount	60*2 pcs
Maximum System Voltage	1500V
Junction Box	IP68
Front glass	3.2mm, Anti-Reflection Coating, High Transmission, Low Iron, Tempered Glass
Frame	Aluminum Alloy
Cable	4mm <sup>2</sup> , N 1200mm/P 1200mm for Horizontal installation 4mm <sup>2</sup> , N 300mm/P 300mm for Vertical installation
Connector	MC4 compatible

## ELECTRICAL PARAMETERS AT STC

Power	480W	485W	490W	495W	500W
Open Circuit Voltage	43.37V	43.52V	43.67V	43.82V	43.97V
Short Circuit Current	13.86A	13.92A	14.00A	14.09A	14.18A
Maximum Power Voltage	35.90V	36.04V	36.19V	36.35V	36.50V
Maximum Power Current	13.37A	13.46A	13.54A	13.62A	13.70A
Module Efficiency	21.65%	21.88%	22.10%	22.33%	22.55%

\* Under Standard Test Conditions (STC) of irradiance of 1000 W/m<sup>2</sup>, spectrum AM 1.5 and cell temperature of 25°C.

## ELECTRICAL PARAMETERS AT NMOT

Power	361W	365W	369W	373W	376W
Open Circuit Voltage	41.23V	41.38V	41.53V	41.68V	41.83V
Short Circuit Current	11.15A	11.22A	11.26A	11.32A	11.36A
Maximum Power Voltage	33.46V	33.61V	33.76V	33.91V	34.06V
Maximum Power Current	10.79A	10.86A	10.93A	11.00A	11.04A

\* Under Nominal Module Operating Temperature (NMOT), irradiance of 800 W/m<sup>2</sup>, spectrum AM 1.5, ambient temperature 20°C, wind speed 1 m/s.

## TEMPERATURE CHARACTERISTICS

NMOT	41±3°C	Temp Coefficient of ISC	+0.046%/°C
Temp Coefficient of VOC	-0.25%/°C	Temp Coefficient of Pmax	-0.30%/°C

## PACKING CONFIGURATION

Modules/Pallet	36 Pieces	Modules/40'Container	864 Pieces
Packing Description	24 Pallets, Total=(36+36)x12=864 Pieces		

## CHARACTERISTICS

LP182\*182-M-60-NH-500W

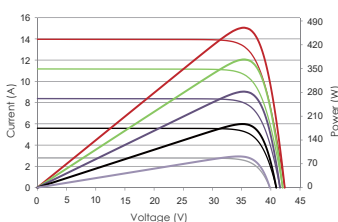

LP182\*182-M-60-NH-500W

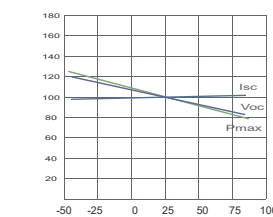

## MAXIMUM RATING

Output Tolerance	0~+5W
Operating Temperature	-40°C~+85°C
Wind Load/Snow Load	2400pa/5400pa
Fuse Current	25A



Headquarter : Lepton Energy Co., Ltd.

☑ Tosei Bldg. 6F, 1-2-1 Aioi-cho, Chuo-ku Kobe-shi, Hyogo, 650-0025, Japan

☎ +81-78-382-3182

🌐 www.leptonenergy.jp

Manufacturer : Lepton Solar (Changshu) Co., Ltd.

☑ No.9, Sunshine Avenue, Changshu City, Jiangsu, China

☎ +86-512-88800068

✉ info@leptonenergy.com

🌐 www.leptonpv.com