



LEAPTON
SOLAR

Monofacial

Bifacial

LP182*182-M-60-NH

N-Type TOPCon

Rated Power 470-490W



N-Type MBB Cell
New circuit design N-type cells, can increase the output power of 10W~20W



Low Light Features
Higher performance under low light environment.



Higher Output Power
Module adopts 120 pcs of 182*182mm half cells, the maximum power can reach 490W.



PID Protection
Ensure the attenuation probability caused by PID phenomenon is minimized.



Harsh Environmental Adaptability
Strict salt spray and ammonia corrosion test by TUV Nord.



Load Capacity
Mechanical load tests including wind load 2400 Pa and snow load 5400 Pa done by TUV Nord.

Leapton N-Type Linear Power Warranty Industry Warranty
0.4% Annual Degradation over 30 years

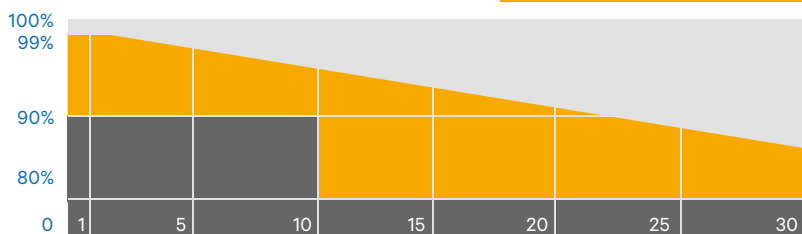

Headquarter : Leapton Energy Co., Ltd.

Tosei Bldg. 6F, 1-2-1 Aioi-cho, Chuo-ku Kobe-shi, Hyogo, 650-0025, Japan

+81-78-382-3182

www.leaptonenergy.jp

Manufacturer : Leapton Solar (Changshu) Co., Ltd.

No.9, Sunshine Avenue, Changshu City, Jiangsu, China

+86-512-88800068

info@leaptonenergy.com

www.leaptonpv.com

MECHANICAL DIAGRAMS

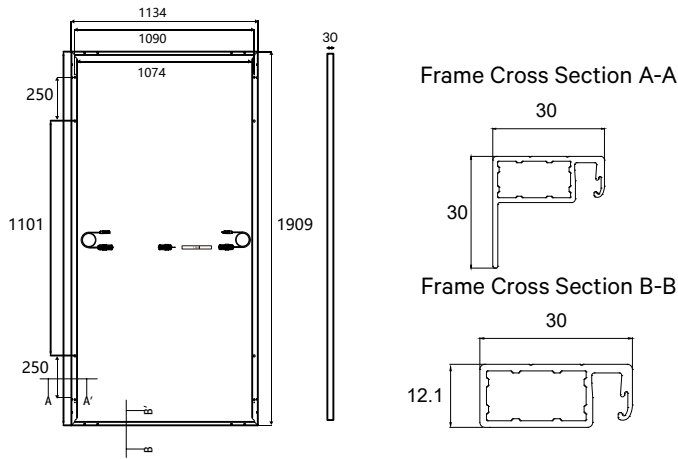

SPECIFICATIONS

Weight	23kg
Dimensions	1909mm*1134mm*30mm
Cell Dimensions	182*182mm
Cell Amount	60*2 pcs
Maximum System Voltage	1500V
Junction Box	IP68
Front glass	3.2mm, Anti-Reflection Coating, High Transmission, Low Iron, Tempered Glass
Frame	Aluminum Alloy
Cable	4mm ² , N 1200mm/P 1200mm for Horizontal installation 4mm ² , N 300mm/P 300mm for Vertical installation
Connector	MC4 compatible

ELECTRICAL PARAMETERS AT STC

Power	470W	475W	480W	485W	490W
Open Circuit Voltage	42.60V	42.75V	42.90V	43.05V	43.20V
Short Circuit Current	13.97A	14.04A	14.12A	14.18A	14.26A
Maximum Power Voltage	35.03V	35.19V	35.32V	35.48V	35.64V
Maximum Power Current	13.42A	13.50A	13.59A	13.67A	13.75A
Module Efficiency	21.71%	21.94%	22.17%	22.40%	22.63%

* Under Standard Test Conditions (STC) of irradiance of 1000 W/m², spectrum AM 1.5 and cell temperature of 25°C.

ELECTRICAL PARAMETERS AT NMOT

Power	354W	358W	361W	365W	369W
Open Circuit Voltage	40.45V	40.60V	40.75V	40.90V	41.05V
Short Circuit Current	11.27A	11.33A	11.36A	11.43A	11.46A
Maximum Power Voltage	32.66V	32.82V	32.97V	33.12V	33.28V
Maximum Power Current	10.84A	10.91A	10.95A	11.02A	11.09A

* Under Nominal Module Operating Temperature (NMOT), irradiance of 800 W/m², spectrum AM 1.5, ambient temperature 20°C, wind speed 1 m/s.

TEMPERATURE CHARACTERISTICS

NMOT	41±3°C	Temp Coefficient of ISC	+0.046%/°C
Temp Coefficient of VOC	-0.25%/°C	Temp Coefficient of Pmax	-0.30%/°C

PACKING CONFIGURATION

Modules/Pallet	36 Pieces	Modules/40'Container	864 Pieces
Packing Description	24 Pallets, Total=(36+36)x12=864 Pieces		

CHARACTERISTICS

LP182*182-M-60-NH-480W

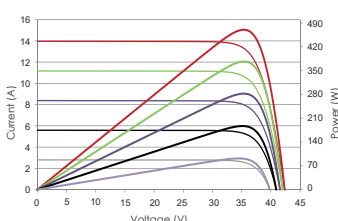

LP182*182-M-60-NH-480W

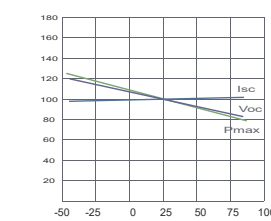

MAXIMUM RATING

Output Tolerance	0~+5W
Operating Temperature	-40°C~+85°C
Wind Load/Snow Load	2400pa/5400pa
Fuse Current	25A



Headquarter : Lepton Energy Co., Ltd.

📍 Tosei Bldg. 6F, 1-2-1 Aioi-cho, Chuo-ku Kobe-shi, Hyogo, 650-0025, Japan

Manufacturer : Lepton Solar (Changshu) Co., Ltd.

📍 No.9, Sunshine Avenue, Changshu City, Jiangsu, China

☎ +81-78-382-3182

🌐 www.leptonenergy.jp

☎ +86-512-88800068

✉ info@leptonenergy.com

🌐 www.leptonpv.com